

ASHCROFT®

YOUR PRESSURE AND
TEMPERATURE SWITCH SOURCE

NEW!
ATEX
APPROVAL
AVAILABLE

B-SERIES SWITCHES
PRESSURE, DIFFERENTIAL
PRESSURE, TEMPERATURE
AND HYDRAULIC

IN A RUSH?
ASK FOR
ASHCROFT
GOLD
SERVICE

NEW!
5000 & 7500
PSI RANGES
AVAILABLE



ISO 9001
REGISTERED FIRM

DRESSER
Instruments

BULLETIN SW-10

B-SERIES PRODUCT INFORMATION

The Dresser Control Instrument Operation supplies highly reliable Ashcroft® switches and controls for industrial and process applications. We begin with rock-solid designs, matching the most appropriate technology with the safety and reliability requirements of the applications. The materials of construction are specified to Dresser's exacting standards, and product is built to last in the toughest applications. Our modern, responsive manufacturing facility in Connecticut is supported by an extensive network of stocking distributors and factory sales offices located in virtually every part of the world. Special application assistance is always just a telephone call away.

The Ashcroft B-Series switch line is designed to satisfy most switch requirements. Materials of construction have been selected for long life. A wide variety of precision switch elements are avail-

able to meet every application requirement, including hermetically sealed contacts for added reliability and safety. The actuators we use have been proven in more than 20 years of service in the world's plants and mills. Special designs are available for fire safety, NACE, limit control and other more stringent requirements. Simplicity and ease of use are stressed to improve reliability of the installation.

B-Series switches have proven reliable in such harsh environments as:

- Offshore oil rigs
- Chemical and petrochemical plants
- Pulp and paper mills
- Steel mills
- Power plants
- Water and sewage-treatment plants
- Other corrosive environments

Type 400 Enclosure

UL and CSA listed instrument quality snap-action switch for reliable operation. Ratings up to 10A dc or 20A ac. Hermetically sealed switch also available.



Applications include: pumps, compressors, washers, filters, degreasers, evaporators, recovery systems, food processing, ground support equipment, reverse osmosis systems, heat exchangers, hydraulic systems, lubrication systems, marine equipment, textile machinery, heating and air conditioning equipment.

Hermetically Sealed Switch

We recommend hermetically sealed switch elements for improved reliability. The hermetically sealed switch provides uncompromising contact protection in harsh or corrosive environments. The Ashcroft 400 Series is also approved for installation in Division II hazardous areas when supplied with hermetically sealed contacts.



- Features:
- UL-recognized component, guide WSQ2, File E85076
 - All-stainless steel welded construction

RECOMMENDED PRACTICE:
All controls should be selected considering the media and ambient operating conditions. Improper application can be detrimental to the switch, cause failure and possibly personal injury or property damage.

The information in this catalog is offered as a guide to assist in making the proper selection of Ashcroft controls.

Additional information is available from Dresser Control Instrument Operations Sales. Offices are listed on the back cover.

Type 700 Enclosure

UL and CSA listed instrument quality snap-action switch for reliable operation. Ratings up to 10A dc or 20A ac. Hermetically sealed switch also available. Dual (2 SPDT) shown.

Epoxy-coated aluminum enclosure and cover for corrosion resistance. Class 1, Division 1 & 2, Groups B, C, D, Class 2, Division 1 & 2, Groups E, F, G, NEMA 7 & 9 and IP66.

Terminal block wiring standard on dual switches. Optional (XK3) on single switches.

Deadband limits for each switch.

High proof pressure.

Buna-N O-ring for sealing enclosure.

Two 3/4 NPT electrical conduit connections.

Standard 316 SS pressure connection. Optional 1/2 NPT shown.

Accessible adjustment is stainless steel for corrosion resistance, includes vibration-resistant feature.

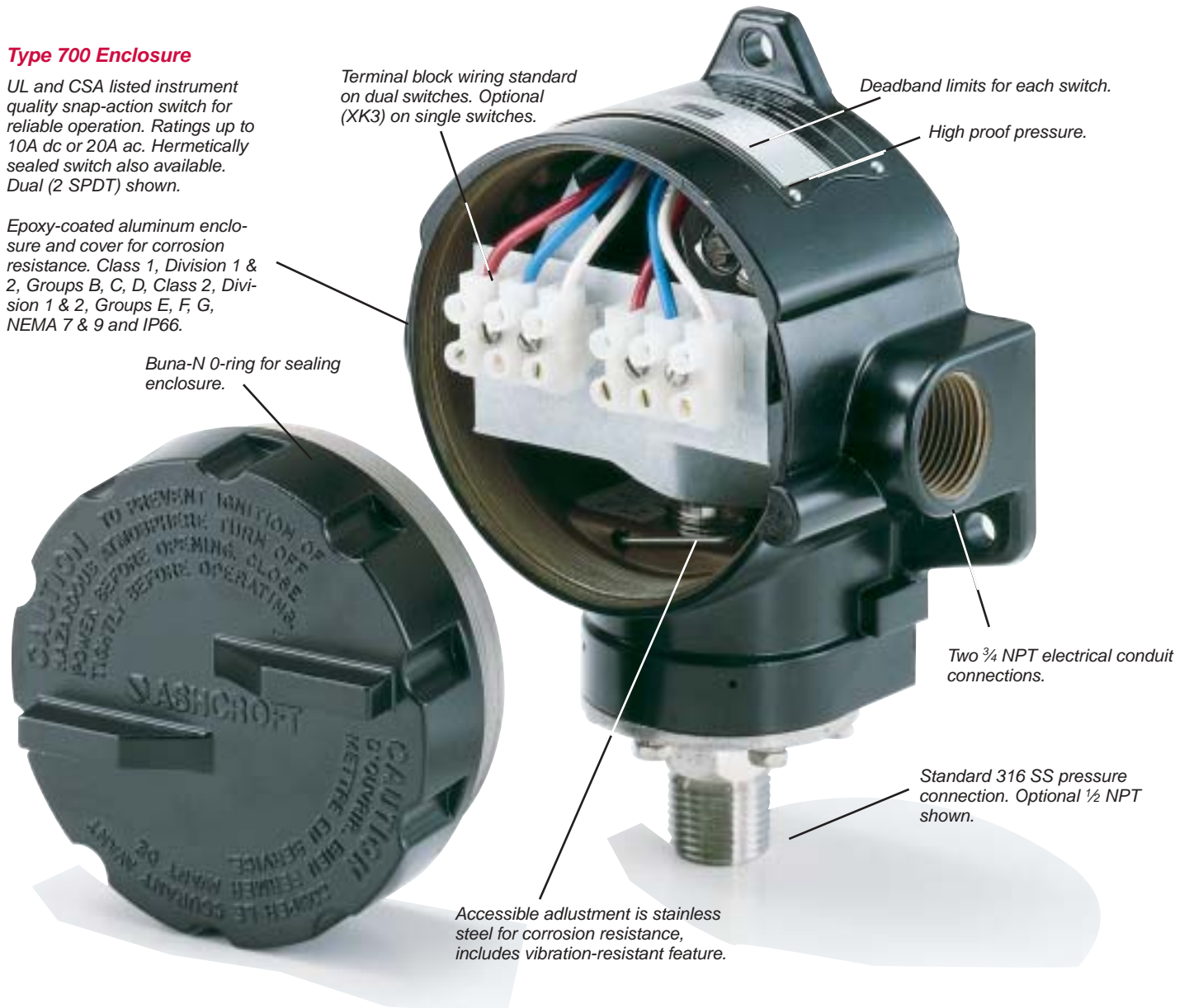

PRESSURE AND DIFFERENTIAL PRESSURE SWITCHES

B-Series pressure, differential pressure and vacuum switches use two different actuators depending on setpoint requirements. For setpoints between 2 and 3000 psi, the simple, rugged diaphragm-sealed piston actuator is used. This design features high reliability and choice of actuator seal materials for virtually every application. An optional welded design is also available for setpoints up to 1000 psi for maximum reliability. This design is available in 316

SS or Monel. Differential pressure models use a unique, dual diaphragm-sealed piston design that features very high static operating pressures and small size.

For setpoints between 4.5 and 150 inches of H₂O, a large diaphragm is used for increased sensitivity in both pressure and differential pressure designs with good choice of materials of construction.

All standard models feature ±1 percent of range setpoint repeatability and a minimum of 400 percent of range proof pressures.

These standard designs perform well in applications where shock and vibration could be a problem and may be used in conjunction with Ashcroft diaphragm seals in extreme services such as slurries or abrasive process fluids.

PRESSURE/VACUUM SWITCHES

Nominal Range ⁽¹⁾			Overpressure Ratings		Approximate Deadband ⁽²⁾ Switch Element				
			Proof psi	Burst psi	20, 26, 27	21, 24, 31	50	22	32
Vacuum									
-30" Hg	-760mm Hg	-100 kPa	500	1000	0.3-0.7	1.5-3.0	0.5-2.2	0.4-1.5	2.1-4.2
Compound									
-15" H ₂ O/ 15" H ₂ O	-375mm H ₂ O/ 375mm H ₂ O	-3.7 kPa/ 3.7 kPa	20	35	0.15-.75/ 0.15-.75	1.5-2.5/ 1.5-2.5	0.45-2.0/ 0.45-2.0	0.5-1.2/ 0.5-1.2	2.1-3.5/ 2.1-3.5
-30" H ₂ O/ 30" H ₂ O	-760mm H ₂ O/ 760mm H ₂ O	-7.5 kPa/ 7.5 kPa	20	35	0.30-.60/ 0.30-.60	1.5-2.5/ 1.5-2.5	0.45-2.0/ 0.45-2.0	0.5-1.5/ 0.5-1.5	2.1-3.5/ 2.1-3.5
-30" Hg/ 15 psi	-760mm Hg/ 1.0 kg/cm ²	-100 kPa/ 100 kPa	500	1000	0.5-1.0/ 0.3-0.7	2.0-3.0/ 0.5-1.5	0.75-2.5/ 0.5-1.0	0.7-1.8/ 0.7-1.4	2.8-4.2/ 0.7-2.1
-30" Hg/ 30 psi	-760mm Hg/ 2.0 kg/cm ²	-100 kPa/ 200 kPa	500	1000	1.0-1.5/ 0.3-0.8	3.0-6.0/ 1.0-2.0	1.2-4.5/ 0.7-1.5	1.4-2.4/ 0.4-1.3	4.2-8.4/ 1.4-2.8
-30" Hg/ 60 psi	-760mm Hg/ 4.0 kg/cm ²	-100 kPa/ 400 kPa	500	1000	2.0-3.0/ 0.7-1.5	5.0-9.0/ 3.0-5.0	2.5-7.0/ 1.1-4.0	2.8-4.5/ 1.0-2.3	7.0-12.0/ 4.2-7.0
Pressure									
10" H ₂ O	250mm H ₂ O	2.5 kPa	20	35	0.2-0.5	1.0-2.0	0.35-1.5	0.4-1.0	1.4-2.8
30" H ₂ O	750mm H ₂ O	7.5 kPa	20	35	0.3-0.6	1.5-2.5	0.45-2.0	0.5-2.0	2.1-3.5
60" H ₂ O	1500mm H ₂ O	15 kPa	20	35	0.5-1.3	1.5-3.5	0.9-2.5	0.7-3.0	2.1-5.0
100" H ₂ O	2500mm H ₂ O	25 kPa	20	35	0.6-1.6	2.5-5.5	1.1-4.0	1.0-4.0	3.5-7.7
150" H ₂ O	3750mm H ₂ O	37 kPa	20	35	1.0-2.5	4.5-8.5	1.7-6.5	2.0-6.0	6.0-12.0
15 psi	1.0 kg/cm ²	100 kPa	2400	3000	0.1-0.35	0.5-1.5	0.2-1.0	0.4-1.0	0.7-2.1
30 psi	2.0 kg/cm ²	200 kPa	2400	3000	0.1-0.50	0.5-1.5	0.3-1.0	0.4-1.0	0.7-2.1
60 psi	4.0 kg/cm ²	400 kPa	2400	3000	0.3-1.0	1.0-3.5	0.7-2.5	0.6-2.0	1.4-5.0
100 psi	7.0 kg/cm ²	700 kPa	2400	3000	0.5-1.7	1.5-5.0	1.1-3.5	1.0-4.5	2.1-7.0
200 psi	14 kg/cm ²	1400 kPa	2400	3000	1-3	5-13	2-9	3.0-7.5	7.0-18.2
400 psi	28 kg/cm ²	2800 kPa	2400	3000	4-7.5	5-24	5.5-15	4.0-11.0	7.0-33.6
600 psi	42 kg/cm ²	4200 kPa	2400	3000	4-11	9-30	7-20	5.0-23.0	12.6-42
1000 psi	70 kg/cm ²	7000 kPa	12000	18000	7-30	30-110	18-70	15-80	42-154
3000 psi	210 kg/cm ²	2100 kPa	12000	18000	15-60	80-235	37-160	30.0-230	112-329

DIFFERENTIAL PRESSURE SWITCHES

Nominal Range ⁽¹⁾			Pressure Ratings		Approximate Deadband ⁽²⁾ Switch Element				
			Static Working Pressure	Proof psi	20, 26, 27	21, 24, 31	50	22	32
30" H ₂ O	750mm H ₂ O	7.5 kPa	5.4	21.6	0.3-0.6	1.5-2.5	0.45-2.0	0.5-2.0	2.1-3.5
60" H ₂ O	1500mm H ₂ O	15 kPa	5.4	21.6	0.5-1.3	1.5-3.5	0.9-2.5	0.7-3.0	2.1-5.0
100" H ₂ O	2500mm H ₂ O	25 kPa	5.4	21.6	0.6-1.6	2.5-5.5	1.1-4.0	1.0-4.0	3.5-7.7
150" H ₂ O	3750mm H ₂ O	37 kPa	5.4	21.6	1.0-2.5	4.5-8.5	1.8-6.5	2.0-6.0	6.3-12.0
15 psid	1.0 kg/cm ²	100 kPa	500	2000	0.5-1.0	2.0-5.0	0.7-3.5	0.7-1.4	2.8-7.0
30 psid	2.0 kg/cm ²	200 kPa	500	2000	1.0-2.0	2.0-5.0	1.5-3.5	1.4-2.8	2.8-7.0
60 psid	4.0 kg/cm ²	400 kPa	500	2000	2.0-4.0	3.0-6.0	3.0-4.5	2.8-5.6	4.2-8.5
100 psid	7.0 kg/cm ²	700 kPa	1000	4000	4.0-10.0	11.0-20.0	7.0-15.0	6.0-14.0	16.0-28.0
200 psid	14.0 kg/cm ²	1400 kPa	1000	4000	5.0-15.0	12.0-40.0	10.0-26.0	7.0-21.0	17.0-56.0
400 psid	28.0 kg/cm ²	2800 kPa	1000	8000	10.0-20.0	20.0-60.0	15.0-40.0	14.0-28.0	28.0-84.0
600 psid	42.0 kg/cm ²	4200 kPa	1000	8000	20.0-40.0	80.0-150.0	30.0-115.0	30.0-56.0	112.0-210.0

Values shown are for zero static working pressure.

NOTES:

1 Switches may generally be set between 15% and 100% of nominal range on increasing pressure. Consult factory for applications where setpoints must be lower.

2 All deadbands are given in English units as shown in the nominal range column. Deadbands shown are for switches with Buna N diaphragm. Approximate deadbands for optional diaphragms:

Viton: Multiply Buna N value by 1.4
 Teflon: Multiply Buna N value by 1.2
 Stainless Steel: Multiply Buna N value by 1.7
 Monel: Multiply Buna N value by 1.7
 Dual Switch Element: Multiply single switch element value by 1.6 for approximate deadband.

ORDER INFORMATION

B-SERIES PRESSURE AND DIFFERENTIAL PRESSURE SWITCH MODEL NUMBER:

To specify the exact switch desired, select entries from appropriate tables as shown in example below.

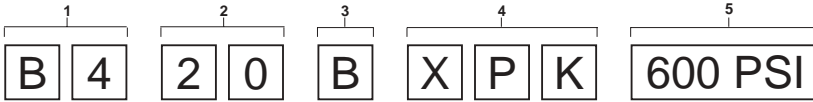

D4 psid model shown

1 – ENCLOSURE

B4	Pressure switch, Type 400, watertight enclosure meets NEMA 3, 4, 4X, 13 and IP66 requirements.
B7	Pressure switch, Type 700, explosion-proof enclosure meets Div. 1 & 2, NEMA 7, 9 and IP66 requirements.
D4	Differential pressure switch, Type 400, watertight enclosure meets NEMA 3, 4, 4X, 13 and IP66 requirements.
D7	Differential pressure switch, Type 700, explosion-proof enclosure meets Div. 1 & 2, NEMA 7, 9 and IP66 requirements.

3 – ACTUATOR SEAL

Code and Material	Process Temperature Limits °F ⁽⁹⁾	Range			
		Vac. ~ H ₂ O	0-600 psi	1000 psi	3000 psi
B – Buna-N	0 to 150	•	•	•	•
V – Viton	20 to 300	•	•	•	
T – Teflon	0 to 150	•	•	•	•
S – 316L ⁽⁸⁾	0 to 300		•	•	
P – Monel ⁽⁸⁾	0 to 300		•	•	

4 – OPTIONS

Use table from page 10

5 – RANGE

Select from table on page 4

2 – SWITCH ELEMENT SELECTION

Order Code	Switch Elements UL/CSA Listed SPDT	
20⁽⁷⁾	Narrow deadband ac	15A, 125/250 Vac
21	Ammonia service	5A, 125/250 Vac
22⁽⁶⁾	Hermetically sealed switch, narrow deadband	5A, 125/250 Vac
23	Heavy duty ac	22A, 125/250 Vac
24⁽¹⁾	General purpose	15A, 125/250/480 Vac 1/2A, 125 Vdc 1/4A, 250 Vdc; 6A, 30 Vdc
25⁽²⁾	Heavy duty dc	10A, 125 Vac or dc, 1/8 HP, 125 Vac or dc
26⁽⁷⁾	Sealed environment proof	15A, 125/250 Vac
27	High temperature 300°F	15A, 125/250 Vac
28⁽⁵⁾	Manual reset trip on increasing	15A, 125/250 Vac
29⁽⁵⁾	Manual reset trip on decreasing	15A, 125/250 Vac
31	Low level (gold) contacts	1A, 125 Vac
32	Hermetically sealed switch, general purpose	11A, 125/250 Vac 5A, 30 Vdc
42	Hermetically sealed switch, gold contacts	1A, 125 Vac
50	Variable deadband	15A, 125/250 Vac
UL/CSA Listed Dual (2 SPDT)		
61⁽⁷⁾	Dual narrow deadband	15A, 125/250 Vac
62⁽⁷⁾	Dual sealed environment proof	15A, 125/250 Vac
63	Dual high temp. 300°F	15A, 125/250 Vac
64	Dual general purpose	15A, 125/250/480 Vac 1/2A, 125 Vdc 1/4A, 250 Vdc
65	Dual ammonia service	5A, 125/250 Vac
67^(4,6)	Dual hermetically sealed switch, narrow deadband	5A, 125/250 Vac
68⁽⁴⁾	Dual hermetically sealed switch, general purpose	11A, 125/250 Vac 5A, 30 Vdc
71⁽⁴⁾	Dual hermetically sealed switch, gold contacts	1A, 125 Vac

NOTES:

- Standard switch.
- Not available with psid ranges.
- Dual switches are 2 SPDT snap-action switches, not independently adjustable.
- Wires cannot be terminated inside B400 switch enclosure.
- Not available with type 700 enclosure.
- Estimated dc. rating, 2.5A, 28 Vdc (not UL listed).
- Estimated dc rating, 0.4A, 120 Vdc (not UL listed).
- Available on pressure only.
- Ambient operating temperature limits -20 to 150°F, all styles, setpoint shift of ±1% of range per 50°F temperature change is normal. Switches are calibrated at 70°F reference.

TEMPERATURE SWITCHES

B-Series temperature switches feature a SAMA Class II vapor pressure thermal system. This system provides quick, accurate response to process temperature changes with negligible ambient temperature effects. This is inherent in the design due to the precise relationship that exists between

temperature and pressure according to the vapor pressure laws. A wide selection of sensing bulb and armored capillary lengths is available. The vapor pressure system design features small bulb sizes, making installation easy and cost-effective.

All models feature $\pm 1.0\%$ percent of

span setpoint repeatability with very high overtemperature ratings.

These standard designs perform well in applications where shock and vibration could be a problem and should be used with Ashcroft thermowells for bulb protection and ease of installation and maintenance.

STANDARD TEMPERATURE RANGE SELECTION

Nominal Range ⁽¹⁾		Maximum Temperature °F	Approximate Deadband ⁽¹⁾ Switch Element				
°F	°C		20, 26, 27	21, 24, 31	50	22	32
-40 to 60	-40 to 16	400	1.0-2.0	3.0-8.0	1.5-5.5	1.4-6.0	8.0-16.0
0 to 100	-20 to 40	400	1.5-3.0	5.0-12.0	2.2-8.5	1.5-7.5	9.0-20.0
75 to 205	20 to 95	400	1.5-3.5	8.0-16.0	2.5-12.0	2.0-9.0	10.0-24.0
150 to 260	65 to 125	400	1.5-3.0	5.0-12.0	2.2-8.5	2.0-9.0	10.0-24.0
235 to 375	110 to 190	500	1.5-3.5	5.0-12.0	2.5-8.5	2.0-9.0	10.0-24.0
350 to 525 ⁽³⁾	175 to 275	700	2.0-4.5	8.0-16.0	3.2-12.0	2.5-10.0	15.0-34.0
500 to 750 ⁽²⁾	260 to 400	900	4.0-8.0	16.0-30.0	7.2-24.0	5.0-23.0	30.0-50.0

NOTES:

- 1 All deadbands given in °F.
- 2 Available with remote mount thermal systems only.
- 3 Not available with 2 $\frac{3}{4}$ " stem.
- 4 Dual switch element multiply single switch element value by 1.6 for approximate deadband.
- 5 Set and reset points must fall within the adjustable range.

THERMOWELLS

Thermowells must be used on any application where the bulb of the temperature switch may be exposed to pressure, corrosive fluids or high velocity. Additionally, the use of a thermowell permits instrument interchange or calibration check without disturbing or closing down the process.

Ashcroft temperature switches have bulb diameters to match $\frac{3}{8}$ " nominal bore thermowells. The bulbs have a sensitive portion length of 2" which can be used with 2 $\frac{1}{2}$ " "U" dimensioned thermowells or longer. For maximum accuracy a thermowell "U" dimension should be selected to permit complete immersion of the sensitive portion plus 1" when measuring the temperature of liquids; an extra 3" should be allowed when measuring the temperature of gases.

Thermowell bushings should be used with remote mount temperature switches. We recommend the standard 3" bulb and code 69 Series bushings for use with any thermowell "U" dimension. A split rubber grommet allows easy installation and "S" dimension adjustment.

To order a thermowell, refer to Price Sheet TH/PS-1 for complete information.

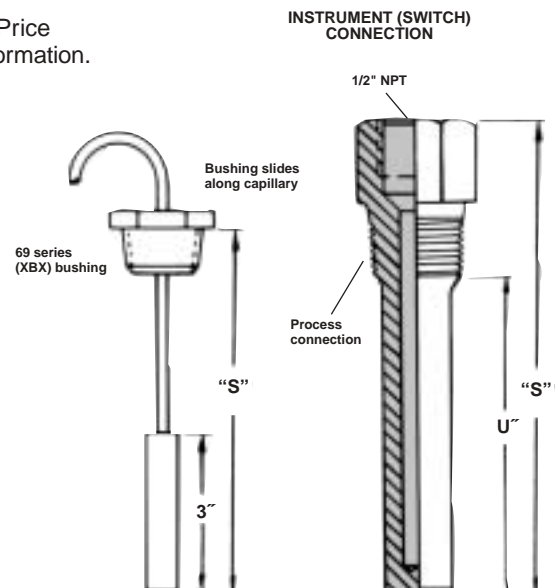

ORDER INFORMATION



T4 direct mount model shown

B-SERIES TEMPERATURE SWITCH MODEL NUMBER:

To specify the exact switch desired, select entries from appropriate tables as shown in example below.

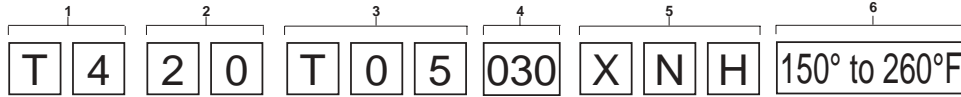

1 – ENCLOSURE	
T4	Temperature switch, Type 400, watertight enclosure meets NEMA 3, 4, 4X, 13 and IP66 requirements.
T7	Temperature switch, Type 700, explosion-proof enclosure meets Div. 1 & 2, NEMA 7, 9 and IP66 requirements.

2 – SWITCH ELEMENT SELECTION		
Order Code	Switch Elements UL/CSA Listed SPDT	
20⁽⁷⁾	Narrow deadband ac	15A, 125/250 Vac
21	Ammonia service	5A, 125/250 Vac
22⁽⁶⁾	Hermetically sealed switch, narrow deadband	5A, 125/250 Vac
23	Heavy duty ac	22A, 125/250 Vac
24⁽¹⁾	General purpose	15A, 125/250/480 Vac ½A, 125 Vdc ¼A, 250 Vdc; 6A, 30 Vdc
25	Heavy duty dc	10A, 125 Vac or dc, ⅛ HP, 125 Vac or dc
26⁽⁷⁾	Sealed environment proof	15A, 125/250 Vac
27	High temperature 300°F	15A, 125/250 Vac
28⁽⁵⁾	Manual reset trip on increasing	15A, 125/250 Vac
29⁽⁵⁾	Manual reset trip on decreasing	15A, 125/250 Vac
31	Low level (gold) contacts	1A, 125 Vac
32	Hermetically sealed switch, general purpose	11A, 125/250 Vac 5A, 30 Vdc
50	Variable deadband	15A, 125/250 Vac
UL/CSA Listed Dual (2 SPDT)		
61⁽⁷⁾	Dual narrow deadband	15A, 125/250 Vac
62⁽⁷⁾	Dual sealed environment proof	15A, 125/250 Vac
63	Dual high temp. 300°F	15A, 125/250 Vac
64	Dual general purpose	15A, 125/250/480 Vac ½A, 125 Vdc ¼A, 250 Vdc
65	Dual ammonia service	5A, 125/250 Vac
67^(4,6)	Dual hermetically sealed switch, narrow deadband	5A, 125/250 Vac
68⁽⁴⁾	Dual hermetically sealed switch, general purpose	11A, 125/250 Vac 5A, 30 Vdc
71⁽⁴⁾	Dual hermetically sealed switch, gold contacts	1A, 125 Vac

3 – THERMAL SYSTEM SELECTION			
Direct Mount			
Order Code	System Material	Style	
TS	316 SS	Rigid	
Remote Mount			
Order Code	System Material	Line Length	Style ⁽⁹⁾
T05	316 SS	5'	Capillary with 302 SS Spring Armor
T10	316 SS	10'	
T15	316 SS	15'	
T20	316 SS	20'	
T25	316 SS	25'	

4 – BULB LENGTH SELECTION		
Direct Mount		
Order Code	“S” Dimension	Minimum Thermowell “U” Dimension
027⁽⁸⁾	2¾"	–
040	4"	2½"
060	6"	4½"
090	9"	7½"
120	12"	10½"
Remote Mount		
030⁽⁹⁾	3"	2½"

5 – OPTIONS
Use table on page 10

6 – STANDARD TEMPERATURE RANGE SELECTION	
Adjustable Range	
°F	°C
–40 to 60	–40 to 16
0 to 100	–40 to 40
75 to 205	20 to 95
150 to 260	65 to 125
235 to 375	110 to 190
350 to 525	175 to 275
500 to 750 ⁽²⁾	260 to 400

NOTES:

- | | |
|---|--|
| <ul style="list-style-type: none"> 1 Standard switch. 2 Available with remote mount thermal systems only. 3 Dual switches are 2 SPDT snap-action switches, not independently adjustable. 4 Wires cannot be terminated inside T400 switch enclosure. 5 Not available with Type 700 enclosure. | <ul style="list-style-type: none"> 6 Estimated dc rating, 2.5A, 28 Vdc (not UL listed). 7 Estimated dc rating, 0.4A, 120 Vdc (not UL listed). 8 Not available on 350 to 525°F. 9 Consult factory on remote mount for bulb lengths other than 3'. |
|---|--|

ORDER INFORMATION



B-SERIES HYDRAULIC PRESSURE SWITCH MODEL NUMBER:

To specify the exact switch desired, select entries from appropriate tables as shown in example below.

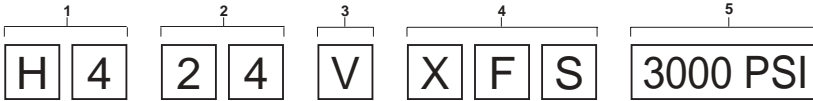

1 – ENCLOSURE

H4	Hydraulic pressure switch, Type 400, watertight enclosure meets NEMA 3, 4, 4X, 13 and IP66 requirements.
-----------	--

3 – ACTUATOR SEAL

Code and Material	Process Temperature Limits °F ⁽⁴⁾	
V – Viton	20 to 300	Viton O-Ring, Stainless Steel Pressure Connection

4 – OPTIONS

Use table from page 10

5 – STANDARD PRESSURE RANGE

Range psi	Adjustable Setpoint Limits psi	Proof Pressure psi
1000	75-1000	12,000
2000	100-2000	12,000
3000	150-3000	12,000
5000	200-5000	12,000
7500	500-7500	12,000

2 – SWITCH ELEMENT SELECTION

Order Code	Switch Elements UL/CSA Listed SPDT	
20 ⁽³⁾	Narrow deadband ac	15A, 125/250 Vac
23	Heavy duty ac	22A, 125/250 Vac
24 ⁽¹⁾	General purpose	15A, 125/250/480 Vac 1/2A, 125 Vdc 1/4A, 250 Vdc; 6A, 30 Vdc
25	Heavy duty dc	10A, 125 Vac or dc, 1/8 HP, 125 Vac or dc
26 ⁽³⁾	Sealed environment proof	15A, 125/250 Vac
27	High temperature 300°F	15A, 125/250 Vac
28	Manual reset trip on increasing	15A, 125/250 Vac
32	Hermetically sealed switch, general purpose	11A, 125/250 Vac 5A, 30 Vdc
UL/CSA Listed Dual (2 SPDT)		
61 ⁽³⁾	Dual narrow deadband	15A, 125/250 Vac
62 ⁽³⁾	Dual sealed environment proof	15A, 125/250 Vac
63	Dual high temp. 300°F	15A, 125/250 Vac
64	Dual general purpose	15A, 125/250/480 Vac 1/2A, 125 Vdc 1/4A, 250 Vdc

NOTES:

- Standard switch.
- Dual switches are 2 SPDT snap-action switches, not independently adjustable.
- Estimated dc rating, 0.4A, 120 Vdc (not UL listed).
- Ambient operating temperature limits –20 to 150°F, all styles, setpoint shift of ±1% of range per 50°F temperature change is normal. Switches are calibrated at 70° F reference.

PRODUCT SELECTION INFORMATION

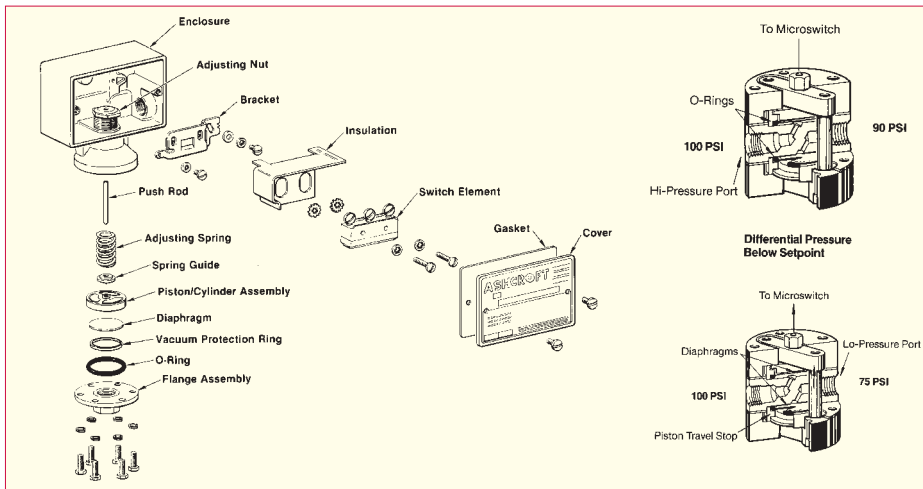

SELECTION

Before making your selection, consider the following:

1. Actuator

The actuator responds to changes in pressure, temperature or differential pressure and operates the switch element in response to these changes.

The actuator is normally exposed to process fluid and must therefore be chemically compatible with it. The following may be used to help select actuator type:

For nominal pressure ranges 0-15 psi through 0-3000 psi, Dresser's standard actuator is a diaphragm-sealed piston. In this actuator, process pressure acting on the piston area causes it to overcome the adjustment spring force and actuate a snap-action switch. A diaphragm and O-ring seal the process media from this mechanism. These are available in various materials, i.e.: Buna N, Teflon and Viton. The standard process connection is stainless steel. Optional Monel pressure connection is available.

For H₂O Pressure and Differential Pressure Ranges, a diaphragm actuator is used. In this design, the standard pressure connections are carbon steel. Diaphragms are available in Viton, Buna N and Teflon. Always review process temperature limits before making seal selections. Optional stainless steel pressure connections are available (option XTA).

For High Differential Pressure Actuator Ranges, 3-15 to 60-600 psid, a Dual Diaphragm-Sealed Piston Actuator is used. This actuator is designed to be used for high static-pressure applications. The standard pressure connections are nickel-plated brass. Diaphragms are available in Viton, Buna N and Teflon. Always review process temperature limits before making seal selections. Optional stainless steel pressure connections are available (option XUD).

For all temperature ranges the standard Ashcroft® temperature actuator operates on the vapor pressure principle: the vapor pressure in a sealed thermal system is applied to a sensing element, which in turn actuates a switch. This is known as a SAMA Class II system. Various filling materials are used, including Propane, Butane, Methyl Alcohol, N Propyl Alcohol and Xylene. High overtemperature capability is possible with this type of system. The interface between liquid and vapor is the point at which sensing occurs. This is the "sensitive" portion of the bulb. Bulb extensions and capillary are normally filled with vapor, and have little effect on the setpoint, regardless of ambient temperature variations; therefore, no ambient compensation is required. For best results, the bulb should be mounted within 60 degrees of vertical to assure the liquid remains in the bulb.

2. Enclosure

The enclosure protects the switch element and mechanism from the environment and has provisions for mounting and wiring. All Ashcroft switch enclosures are epoxy-coated aluminum or stainless steel for maximum corrosion resistance. Choose between watertight NEMA 4, 4X for most industrial applications and explosion-proof NEMA 7/9 for most process applications.

Ashcroft enclosures include watertight cover gaskets, external mounting holes and one or two 3/4 NPT electrical conduit holes for ease of installation. Pressure switches may also be mounted directly to the process by means of the standard 1/4 NPT or optional 1/2 NPT pressure connection.

Note: When installing Ashcroft switches, refer to instruction sheets included with each switch, the National Electrical Code, and any other local codes or requirements to assure safety.

3. The Switching Function

Next, consider the switching function. Most applications for alarm

and shutdown are satisfied by single setpoint, fixed deadband models. For high/low or alarm and shutdown, the dual setpoint models may be selected. For pump, compressor, level and other control applications, an adjustable deadband model is often the best choice. Consult your Ashcroft representative for dual setpoint or adjustable-deadband pressure and temperature switches.

4. The Switch Element

Finally, the electrical switching element must be compatible with the electrical load being switched. For ease of selection, all electrical switching elements are snap acting, SPDT (single pole-double throw), or 2 (SPDT). Refer to catalog pages for switch element choices. Select a switch element with electrical rating that exceeds the electrical rating of the device being controlled by the switch. For better reliability and safety, optional Hermetically Sealed switching elements may be specified.

ADDITIONAL SWITCH TERMINOLOGY

Accuracy – (See repeatability) Accuracy normally refers to conformity of an indicated value to an accepted standard value. There is no indication in switch products; thus, instead, the term repeatability is used as the key performance measure. Ashcroft® pressure and temperature switch accuracy is 1% of nominal range.

Automatic Reset Switch – Switch which returns to normal state when actuating variable (pressure or temperature) is reduced.

Adjustable or Operating Range – That part of the nominal range over which the switch setpoint may be adjusted. Normally about 15% to 100% of the nominal range for pressure and differential pressure switches and the full span for temperature switches.

Burst Pressure – The maximum pressure that may be applied to a pressure switch without causing leakage or rupture. This is normally at least 400% of nominal range for Ashcroft switches. Switches subjected to pressures above the nominal range can be permanently damaged. Consult factory for switches that must operate at pressure above nominal range or reference calibration temperature (70°F).

Deadband – The difference between the setpoint and the reset point, normally expressed in units of the actuating variable. Sometimes referred to as differential.

Division 1 – A National Electrical Code Classification of hazardous locations. In Division 1 locations, hazardous concentrations of flammable gases or vapors exist continuously, intermittently or periodically under normal conditions; frequently because of repair or maintenance operation/leakage or due to breakdown or faulty operation of equipment or processes which might also cause simultaneous failure of electrical equipment. Explosion-proof NEMA 7/9 enclosures are required in Division 1 locations.

Division 2 – A National Electrical Code Classification of Hazardous locations. In Division 2 hazardous locations, flammable or volatile liquid or flammable gases are handled, processed or used, but will normally be confined within closed containers or closed systems from which they can escape only in case of accidental rupture or breakdown or in case of abnormal operation of equipment. Either Nema 7/9 explosion-proof enclosures or any enclosure with hermetically sealed switch contacts may be used in Division 2 locations.

Explosion Proof – A term commonly used in industry referring to enclosures capable of withstanding an internal explosion of a specified gas without igniting surrounding gases. Strict installation practices in accordance with the national electrical code are also required for safety.

Fixed Deadband – The difference between the setpoint and the reset point of a pressure or temperature switch. It further signi-

fies that this deadband is a fixed function of the pressure switch and not adjustable.

Hermetically Sealed Switch – A switch element whose contacts are completely sealed from the environment to provide additional safety and reliability. Contact arc cannot cause an explosion, and atmospheric corrosive elements cannot affect the contacts.

Manual Reset Switch – Pressure or Temperature switch in which contacts remain actuated even after the actuating variable returns to normal. On Ashcroft manual reset switches, a button must be pushed to reset the contacts.

National Electrical Manufacturers Association (NEMA) – This group has defined several categories of enclosures, usually referred to as "types." Further, they designate certain features and capabilities each type must include. For example, among other features, a NEMA 4 enclosure must include a threaded conduit connector, external mounting provision and cover gaskets. When selecting a NEMA 4 enclosure from any manufacturer, a buyer is assured of receiving these features.

NEMA 4 – Watertight and dusttight enclosures intended for use indoors or outdoors to protect the equipment against splashing, falling or hose-directed water, external condensation and water seepage. They are also sleet-resistant.

NEMA 4X – Watertight, dusttight and corrosion-resistant enclosures with same qualifications as NEMA 4, but with added corrosion resistance.

NEMA 7 – Enclosures for indoor Class I, Division 1 Hazardous locations with gas or vapor atmospheres.

NEMA 9 – Enclosures for indoor Class II, Division 1 Hazardous locations with combustible dust atmospheres.

Normal Switch Position – Contact position before actuating pressure (or variable) is applied. Normally closed contacts open when the switch is actuated. Normally open contacts close when the switch is actuated.

Normally Closed – Refers to switch contacts that are closed in the normal switch state or position (unactuated). A pressure change opens the contacts.

Normally Open Switch – Refers to the contacts that are open in the normal switch state or position (unactuated). A pressure change closes the contacts.

Overpressure Rating(s) – A nonspecific term that could refer to either burst or proof pressure, or both.

Proof Pressure – The maximum pressure which may be applied without causing damage. This is determined under strict laboratory conditions including controlled rate of change and temperature: This value is for reference only. Consult factory for applications where switch must operate at pressures above nominal range, or reference calibration temperature (70°F).

Repeatability (Accuracy) – The closeness of agreement among a number of consecutive measurements of the output setpoint for the same value of the input under the same operating conditions, approaching from the same direction, for full-range traverses. Ashcroft® pressure and temperature switch repeatability is 1% of nominal range.

Note: It is usually measured as nonrepeatability and expressed as repeatability in percent of span or nominal range. It does not include hysteresis or deadband.

Reset Point – The reset point is the Pressure, Temperature or Differential Pressure Value where the electrical switch contacts will return to their original or normal position after the switch has activated.

Setpoint – The setpoint is the Pressure, Temperature or Differential Pressure value at which the electrical circuit of a switch will change state or actuate. It should be specified either on increase or decrease of that variable. (See also reset point.)

Single-Pole Double Throw (SPDT) Switching Element – A SPDT switching element has one normally open, one normally closed, and one common terminal. The switch can be wired with the circuit either normally open (N/O) or normally closed (N/C). SPDT is standard with most Ashcroft pressure and temperature switches.

Snap Action – In switch terminology, snap action generally refers to the action of contacts in the switch element. These contacts open and close quickly and snap closed with sufficient pressure to firmly establish an electrical circuit. The term distinguishes products from mercury bottle types that were subject to vibration problems.

Static Pressure – For differential pressure switches, static pressure refers to the lower of the two pressures applied to the actuator.

OPTIONAL FEATURES AND ACCESSORIES

B-SERIES SWITCH OPTIONS

Code	Description	Applicable Switch Series						Notes
		Pressure		Differential Pressure		Temp-erature	H	
		(psi)	(in. H ₂ O)	(psi)	(in. H ₂ O)	All Ranges		
XBP	Wall Mounting Bracket in. H ₂ O		•		•			
XBX	½" Male NPT Bushing					•		
XCH	Chained Cover	•	•	•	•	•	•	
XC8	CSA Approval	•	•	•	•	•		11
XCN	ATEX Directive 94/9/EC EEx d IIC T6	•	•	•	•	•		
XFM	FM Approval – Single Element	•	•	•	•			17
	FM Approval – Dual Element	•	•	•	•			17
XFP	Fungus Proofing	•	•	•	•	•	•	
XFS	Factory Adjusted Setpoint	•	•	•	•	•	•	2
XG3	Belleville Actuator	•						16,17
XG4	Teflon Actuator and Pressure Conn.	•						8
XG5	UL Limit Control to 150" H ₂ O				•			1, 17
XG6	UL Limit Control to 600 psi	•						1, 17
XG7	Secondary Chamber with Vent	•						13
XG8	Steam Limit Control to 300 psi	•						7
XG9	Fire Safe Welded Actuator	•						7
XHS	High Static Diflerential Pressure			•				15
HHX	High Pressure, 40 psi, (static) DIP							
	160 psi (proof) DIP		•		•			
	100 psi proof pressure							
XJK	Left Conduit Connection	•	•	•	•	•	•	9
XJL	¾" to ½" Reducing Bushing	•	•	•	•	•	•	
XK3	Terminal Block (700 Series only)	•	•	•	•	•	•	6
XLE	Long Leads on the Micro Switch	•	•	•	•	•	•	
XL9	Low Hardness SS Press. Conn.	•						12
XNH	Tagging Stainless Steel	•	•	•	•	•	•	
XNN	Paper Tag	•	•	•	•	•	•	
XPK	Pilot Light(s) Top Mounted	•	•	•	•	•	•	4
XPM	¾" Sealed Conduit Connection with 16" Lead Wires	•	•	•	•	•	•	
XTA	316 Stainless Steel Pressure Connection for in. H ₂ O Range		•		•			
XTM	2" Pipe Mounting Bracket	•	•	•	•	•		
XUD	316 Stainless Steel Pressure Conn.			•				
X06	Pressure Connection: ½ NPT Male, ¼ NPT Female	•	•	•	•			5
	316 Stainless Steel (Combination)							
X07	½ NPTF Press. Conn., 316 SS	•	•	•	•			10
X2B	Breather Drain	•	•	•	•	•		
X6B	Cleaned for Oxygen Service	•	•	•				3
	Diaphragm Seal	•	•	•	•			

ATEX Directive 94/9/EC APPROVAL FOR HAZARDOUS LOCATIONS

ATEX is a European designation that deals with standards for equipment and protective systems intended for use in potentially explosive atmospheres. This approval is required for switches intended for use in hazardous locations, especially important to OEMs who export to Europe and contractors specifying or purchasing products for European applications. XCN option adds special features to Ashcroft 700-Series switch enclosures that meet the requirements for the highest levels of security and danger, such as:

- Special locking device requiring an Allen wrench to remove cover
- Special vents that blow out should the diaphragm rupture, thus preventing pressure build-up in the enclosure
- Special conduit plug requiring an Allen wrench for removal
- Available on pressure, temperature and differential pressure models
- Meets Explosion Class EEx d IIC T6



Order option XCN

NOTES:

- 1 Buna N and Viton diaphragm.
- 2 Advise static or working pressure for differential pressure switches.
- 3 Buna N cannot be cleaned for oxygen service.
- 4 N/A on 700 Series.
- 5 Standard with 1000 and 3000 psi ranges. Bottom connection only on DP in H₂O ranges.
- 6 Terminal Blocks standard with 700 dual switches.
- 7 Stainless steel diaphragm only.
- 8 Pressure connection ¼ NPTF.
- 9 Standard on 700 Series. N/A with DPDT element on 400 Series.
- 10 N/A with Monel diaphragm.
- 11 Standard on 400 Series.
- 12 N/A on 3000 psi range. Available with Teflon diaphragm only.
- 13 SS diaphragm required. Teflon diaphragm is the backup. NEMA 7 only.

- 14 Available in ranges vacuum to 600 psi. Not available with stainless steel or Monel diaphragm.
- 15 Buna N and Viton diaphragm – 15#D & 30#D only.
- 16 24, 32, 64 or 68 element only.
- 17 N/A on all combinations

OPTIONAL FEATURES AND ACCESSORIES

XG9 – FIRE-SAFE WELDED ACTUATOR

Standard features:

- 3000 psi burst pressure unrestrained at room temperature
- long service life
- all welded – no O-rings
- built-in over range protection
- superior corrosion resistant materials
- interchangeable with current Ashcroft pressure switch actuators
- 15 psi to 600 psi ranges available

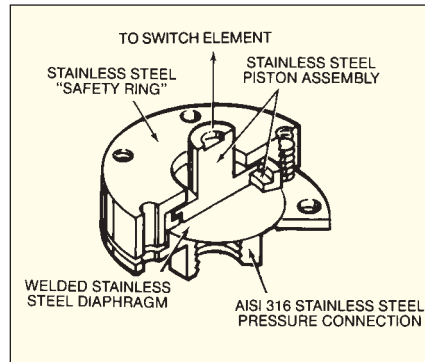

The Ashcroft pressure switch actuator is designed to satisfy most medium range pressure switch applications. It has only two wetted parts; pressure port and diaphragm. No O-rings are required because all joints are welded.

XG6 – U.L. LISTED LIMIT CONTROL SWITCH

Standard features:

- setpoint indicating scale
- adjusting nut stop
- secondary chamber with vent
- optional pilot light for FM requirements

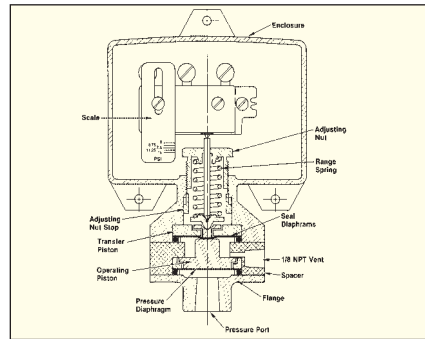

The Ashcroft medium pressure gas and oil limit control switch is designed for use with air, LP gas, natural gas, #1 and #2 fuel oil and #6 oil preheated to 240°F. This limit control is an adjustable pressure operated switch with a secondary chamber to prevent fuel from entering the switch enclosure in the unlikely event that the diaphragm develops a leak. The control shuts down a fuel pump in high or low pressure conditions.

XG8 – U.L. LISTED STEAM LIMIT CONTROL SWITCH

Standard features:

- 316 stainless steel welded diaphragm
- setpoint indicating scale
- adjusting nut stop

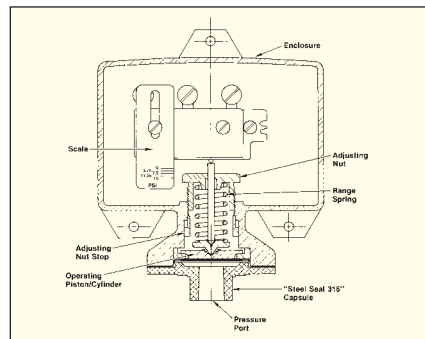

The Ashcroft steam limit control switch is designed for use on boilers equipped with electrically operated burners. The limit control is an adjustable pressure operated switch set to stop burner operation when the recommended safe boiler working pressure is exceeded.

DIAPHRAGM SEALS



Any of the complete line of Ashcroft diaphragm seals may be used with most Ashcroft switches. See Bulletin DS-1.

TYPE 400 DIMENSIONS

Pressure switch – psi ranges

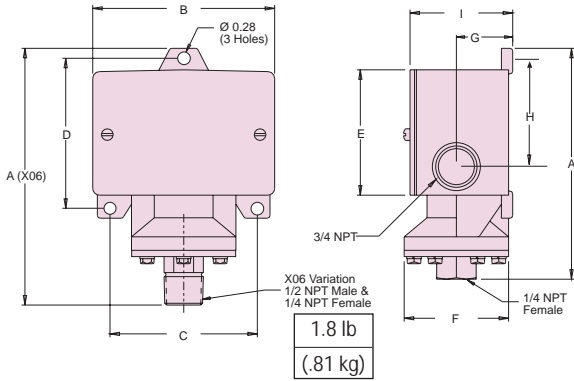

A (X06)	A	B	C	D	E	F	G	H	I
5 ⁷ / ₈	5 ¹ / ₈	4	3 ¹ / ₄	3 ⁵ / ₁₆	2 ³ / ₄	2 ⁵ / ₁₆	1 ¹ / ₄	2 ¹³ / ₃₂	2 ⁵ / ₁₆
(149)	(130)	(102)	(83)	(84)	(70)	(59)	(32)	(61)	(59)

Differential pressure switch – psi differential ranges

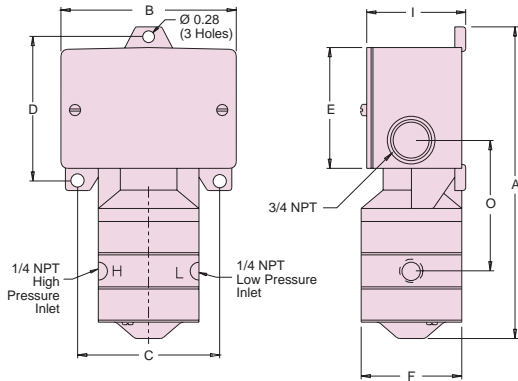

A	B	C	D	E	F	I	O	
7 ⁵ / ₃₂	4	3 ¹ / ₄	3 ⁵ / ₁₆	2 ³ / ₄	2 ⁵ / ₁₆	2 ⁵ / ₁₆	3	3.6 lb
(182)	(102)	(83)	(84)	(70)	(59)	(59)	(56)	(1.6 kg)

Temperature switch – direct mount

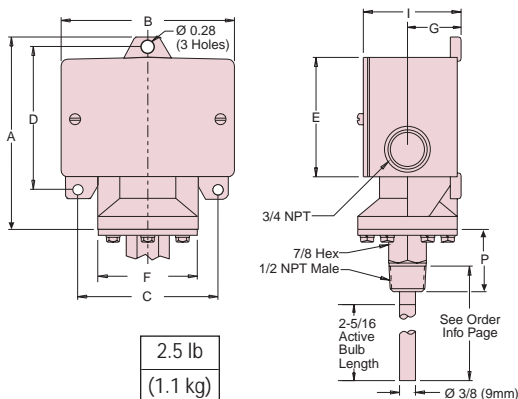

A	B	C	D	E	F	G	I	P
4 ¹¹ / ₁₆	4	3 ¹ / ₄	3 ⁵ / ₁₆	2 ³ / ₄	2 ⁵ / ₁₆	1 ¹ / ₄	2 ⁵ / ₁₆	1 ⁵ / ₁₆
(119)	(102)	(83)	(84)	(70)	(59)	(32)	(59)	(33)

Pressure switch – inches of water ranges

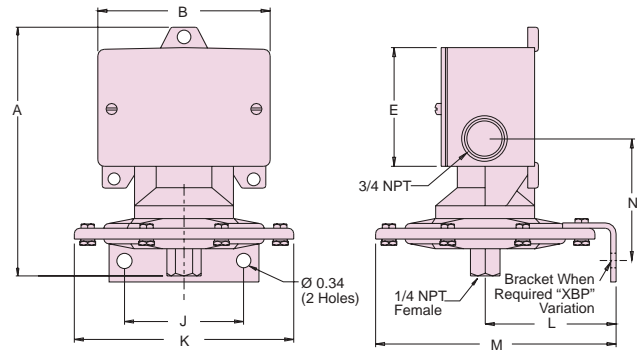

A	B	E	J	K	L	M	N	
5 ²⁵ / ₃₂	4	2 ³ / ₄	2 ²⁵ / ₃₂	5 ¹ / ₈	3 ¹ / ₁₆	5 ¹¹ / ₁₆	2 ²⁷ / ₃₂	2.7 lb
(147)	(102)	(70)	(71)	(130)	(78)	(145)	(72)	(1.2 kg)

Differential pressure switch – inches of water ranges

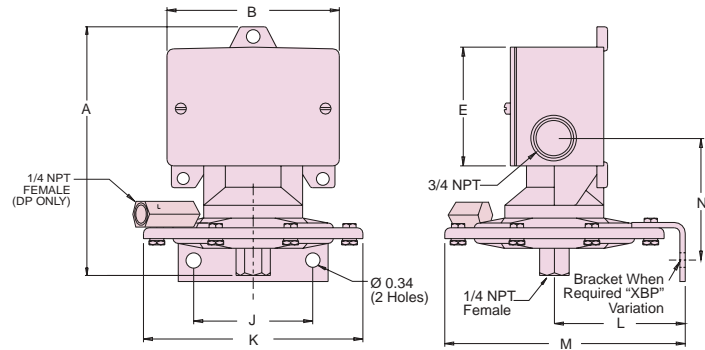

A	B	E	J	K	L	M	N	
5 ²⁵ / ₃₂	4	2 ³ / ₄	2 ²⁵ / ₃₂	5 ¹ / ₈	3 ¹ / ₁₆	5 ¹¹ / ₁₆	2 ²⁷ / ₃₂	2.7 lb
(147)	(102)	(70)	(71)	(130)	(78)	(145)	(72)	(1.2 kg)

Temperature switch – remote mount

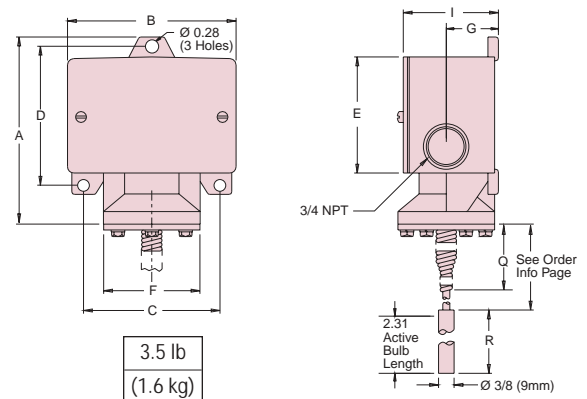

A	B	C	D	E	F	G	I	Q	R
4 ¹¹ / ₁₆	4	3 ¹ / ₄	3 ⁵ / ₁₆	2 ³ / ₄	2 ⁵ / ₁₆	1 ¹ / ₄	2 ⁵ / ₁₆	3	3
(119)	(102)	(83)	(84)	(70)	(59)	(32)	(59)	(76)	(76)

TYPE 700 DIMENSIONS

Pressure switch – psi ranges

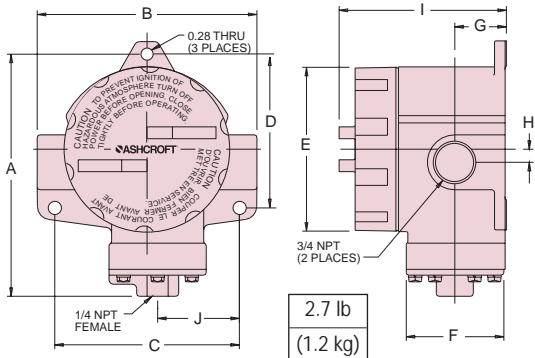

A	B	C	D	E	F	G	H	I	J
5 ³ / ₄	5 ⁷ / ₃₂	4 ³ / ₈	3 ⁵ / ₈	3 ⁷ / ₈	2 ⁵ / ₁₆	1 ⁷ / ₃₂	5 ¹ / ₁₆	3 ³¹ / ₃₂	1 ¹⁵ / ₁₆
(146)	(133)	(111)	(92)	(98)	(59)	(31)	(8)	(101)	(49)

Pressure switch – inches of water ranges

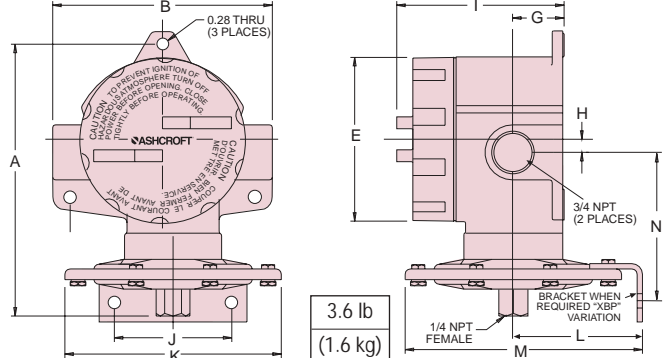

A	B	E	G	H	I	J	K	L	M	N
6 ⁷ / ₁₆	5 ⁷ / ₃₂	3 ⁷ / ₈	1 ⁷ / ₃₂	5 ¹ / ₁₆	3 ³¹ / ₃₂	2 ²⁵ / ₃₂	5 ¹ / ₈	3 ¹ / ₁₆	5 ¹¹ / ₁₆	3 ¹ / ₂
(164)	(133)	(98)	(31)	(8)	(101)	(71)	(130)	(78)	(145)	(89)

Differential pressure switch – psi differential ranges

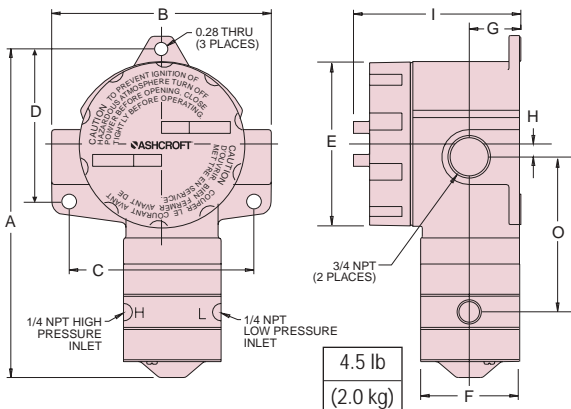

A	B	C	D	E	F	G	H	I	O
7 ²⁵ / ₃₂	5 ⁷ / ₃₂	4 ³ / ₈	3 ⁵ / ₈	3 ⁷ / ₈	2 ⁵ / ₁₆	1 ⁷ / ₃₂	5 ¹ / ₁₆	3 ³¹ / ₃₂	3 ¹¹ / ₁₆
(198)	(133)	(111)	(92)	(98)	(59)	(31)	(8)	(101)	(94)

Differential pressure switch – inches of water ranges

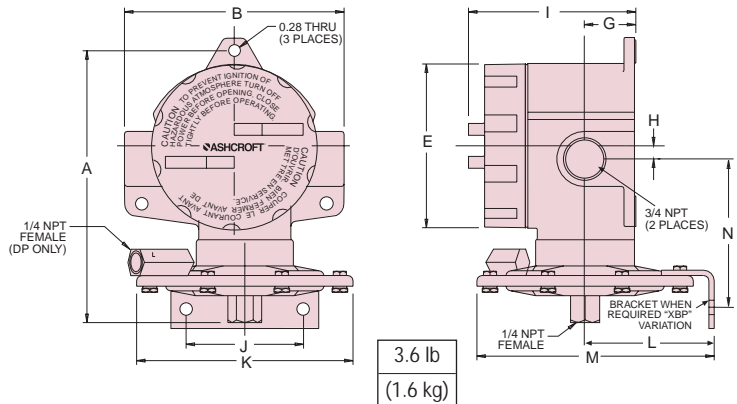

A	B	E	G	H	I	J	K	L	M	N
6 ⁷ / ₁₆	5 ⁷ / ₃₂	3 ⁷ / ₈	1 ⁷ / ₃₂	5 ¹ / ₁₆	3 ³¹ / ₃₂	2 ²⁵ / ₃₂	5 ¹ / ₈	3 ¹ / ₁₆	5 ¹¹ / ₁₆	3 ¹ / ₂
(164)	(133)	(98)	(31)	(8)	(101)	(71)	(130)	(78)	(145)	(89)

Temperature switch – direct mount

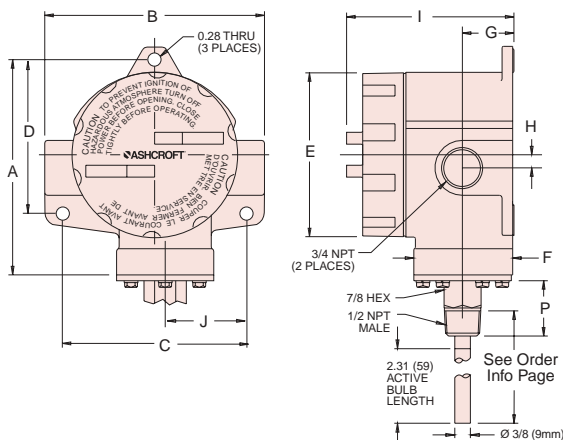

A	B	C	D	E	F	G	H	I	J	P
5 ³ / ₃₂	5 ⁷ / ₃₂	4 ³ / ₈	3 ⁵ / ₈	3 ⁷ / ₈	2 ⁵ / ₁₆	1 ⁷ / ₃₂	5 ¹ / ₁₆	3 ³¹ / ₃₂	1 ¹⁵ / ₁₆	1 ⁵ / ₁₆
(129)	(133)	(111)	(92)	(98)	(59)	(31)	(8)	(101)	(49)	(33)

Temperature switch – remote mount

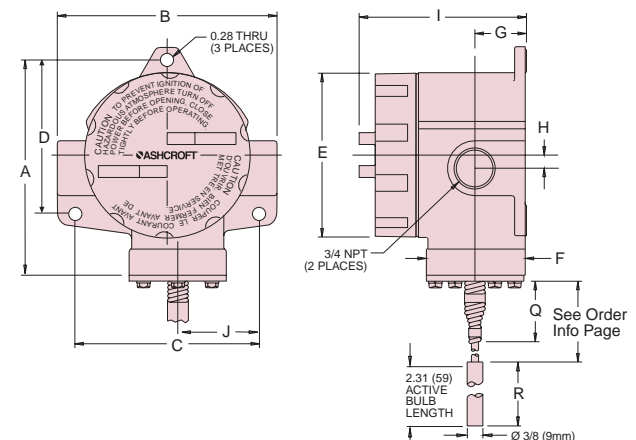

A	B	C	D	E	F	G	H	I	J	Q	R
5 ³ / ₃₂	5 ⁷ / ₃₂	4 ³ / ₈	3 ⁵ / ₈	3 ⁷ / ₈	2 ⁵ / ₁₆	1 ⁷ / ₃₂	5 ¹ / ₁₆	3 ³¹ / ₃₂	1 ¹⁵ / ₁₆	3	3
(129)	(133)	(111)	(92)	(98)	(59)	(31)	(8)	(101)	(49)	(76)	(76)

ADDITIONAL PRESSURE AND TEMPERATURE SWITCH APPLICATION INFORMATION

DIFFICULT PROCESS MEDIA

When specifying pressure or temperature switches, the material in contact with media must be compatible with it. Otherwise, failure could occur, resulting in leakage, injury, and loss of life, property or production. The user should review prior experience with materials of construction in the process for guidance in material selection. If this is not appropriate, contact Dresser's Control Instrument Operation for assistance. Relevant information such as process media, concentration of each constituent, temperature, pressure, the presence of contaminants, particulate, vibration or pulsation is necessary to make the best recommendation. Refer also to Product Information Page ASH-PI-14B "Corrosion Data Guide."

Some applications are best handled by adding an Ashcroft diaphragm seal to isolate the fluid media from the pressure or differential pressure switch.

Diaphragm seals are recommended where:

- The process media being sensed could clog the pressure element.
- The process media temperature is above or below the ratings of the actuator seal materials.
- The application calls for a sanitary process connection.

Note: The addition of a diaphragm seal may increase the deadband and response time of the pressure switch to process pressure changes. Please consult the Control Instrument Operation for details.

Refer also to Ashcroft Product Bulletin DS-1 and Product Information Page SW/PI-30B, "Switch, Diaphragm Seal Combination."



OXIDIZING MEDIA

When specifying a pressure switch for use in oxidizing media, such as chlorine, oxygen and several other chemical compounds, the wetted materials must be compatible with the media, and the switch should be cleaned for oxygen service. This is necessary to remove any residue that might react violently with the oxidizing media. Specify option X6B (clean for oxygen service). Refer also to Product Information Page SW/PI-6B, "Oxygen Cleaning for Ashcroft Switches."

STEAM SERVICE

In order to prevent live steam from coming into contact with the switch actuator, a siphon filled with water should be installed between the switch and the process line. We recommend the optional stainless steel welded process connection and diaphragm even though Viton is rated for use with steam. Experience has shown that in many steam applications, the 300°F high temperature limit of Viton is exceeded by steam under pressure.



In some boiler applications, a special U.L. listing, "MBPR," which requires unique features, is needed. Dresser offers these features with option XG8. Refer also to Product Information Page SW/PI-27A, "Steam Limit Control Switch."

NACE

The National Association of Corrosion Engineers (NACE) publishes a standard covering the requirements of metallic materials in contact with process media containing Hydrogen Sulfide. We recommend the use of Monel (code P) wetted materials for most applications. Other alternatives include adding applicable diaphragm seals or low hardness stainless steel pressure connection (XL9) and teflon diaphragm. Refer also to Product Information Page SW-22A, "Pressure Switches Meeting NACE Standard MR-01-75."

HIGH TEMPERATURE PROCESS

Refer to the actuator seal table for process temperature limits for pressure switch actuators. Pressure switches mounted directly to the process can withstand up to 300°F when equipped with optional Viton, stainless steel or Monel wetted parts. If process temperature exceeds 300°F, four feet of 1/2" tubing between the process and the switch will generally protect the switch from damage.

Alternatively, an Ashcroft diaphragm seal selected from bulletin DS-1 can be used to isolate the switch from the hot process.

VIBRATION

Generally, vibration will not harm Ashcroft pressure switches. However, premature tripping may occur under severe conditions. This tends to be annoying, but repeatable for a given situation and might be in the order of 5% to 10% of switch range from the set-point, i.e. a 100 psi switch set at 50 psi on increasing pressure might trip somewhere between 40 and 45 psi on increasing pressure. This would not reduce the life of the pressure switch.

The best approach in this type of application is to mount the switch remotely, connecting the switch to the process or equipment with flexible tubing. If this is not possible, consider the use of the Belleville actuator, option XG3. Refer also to Product Information Page SW/PI-58, "Belleville Actuator."



PULSATION

Pressure pulsation below the range of the pressure switch will not harm it. However, because the switch can react to pressure pulses less than one-second duration, it might be desirable to include a dampening device. Several Ashcroft accessories such as snubbers address this situation. Refer to the accessory section of Ashcroft Ordering Handbook (OH-1), or consult your Ashcroft representative for more information.

MOUNTING

All Ashcroft pressure, temperature and differential pressure switches with snap acting contacts may be mounted in any position. This includes the sensing bulbs of temperature switches. This is an important advantage of snap acting switch designs.

ADDITIONAL PRESSURE AND TEMPERATURE SWITCH APPLICATION INFORMATION

SWITCH ELEMENT SELECTION

B-Series switches are available with a wide variety of snap acting switch elements to meet most electrical requirements. The standard contact arrangement is single pole, double throw (S.P.D.T.). This includes both normally open and normally closed contacts. Standard contact material is fine silver which generally is suitable for switching 8 volts or more, up to the rating in the Switch Element Selection Table. When switching less than 8 volts, optional Gold Alloy contacts are recommended.

Optional dual, or 2 S.P.D.T. contacts may be supplied in B-Series enclosures for applications requiring two switch functions at the same setpoint. These contacts are technically not double pole, double throw (D.P.D.T.). They are synchronized at the factory to actuate within 1% of nominal range of each other. For simultaneous actuation of 2 S.P.D.T. contacts, option XG3 should be ordered. Refer also to SW/PI-58 "Belleville Actuator".

HAZARDOUS LOCATIONS

a. Division I.

Ashcroft 700 series or other explosion proof enclosures are required to meet the requirements of Division I Hazardous Locations as defined by the National Electrical Code.



ATEX option shown

b. Division II.

These enclosures also meet the less stringent requirements for Division II Hazardous Locations. Alternatively, Ashcroft 400 series or other watertight enclosures with hermetically sealed switch elements are approved for use in Division II hazardous locations.

c. Intrinsic Safety.

Ashcroft 400 and 700 series pressure and temperature switches may be used with approved barriers in most intrinsically safe systems. These switches do not create or store energy and are therefore designated "simple devices" in these systems.

d. ATEX Approval. (optional)

Ashcroft 700 series pressure and temperature switches are approved for ATEX directive 94/9/EC. This European directive is for equipment intended for use in potentially explosive atmospheres. See option XCN on page 10.

INFORMATION & GUIDELINES FOR SETTING ASHCROFT PRESSURE, TEMPERATURE AND DIFFERENTIAL PRESSURE SWITCHES

All Ashcroft pressure, temperature and differential pressure switches can be set at any point between about 15% and 100% of the range as designated on the label or the nominal range table.

Ashcroft pressure and temperature switches can be either set in the field or ordered from the factory preset to your requirements. When set at the factory, the specification is $\pm 1\%$ of the nominal range. Factory setting, or XFS, is a very popular option, and as a result, we often receive orders that do not have enough information or have incorrect information.

HOW TO ORDER

When "XFS" is desired:

1. Setpoint must be indicated.
2. Increasing or decreasing pressure must be indicated.
Ex: B424B XFS 100#
Set: 60# decreasing
3. For differential pressure switches, static operating pressure must also be specified.



For other Ashcroft switch models request Ashcroft Bulletin, Switch Quick Guide QG-3. All product information pages mentioned in this bulletin can be downloaded from our web site.

Instrument Division Sales and Customer Service Locations

U.S. & International Headquarters

Dresser Instruments
Dresser, Inc.
250 East Main Street
Stratford, CT 06614-5145
USA
Tel: (203) 378-8281
Fax: (203) 385-0408

International Operations

Brazil

Dresser Industria e Comercio Ltda.
Rua Senador Vergueiro #433
09521-320 Sao Caetano do Sul
Sao Paulo, Brazil
Tel: 55-11-4224-7400
Fax: 55-11-4224-7477
E-Mail: vendas.instrumentos@dresser.com

Brazil (Jacarei)

Dresser Industria e Comercio Ltda.
Divisao Masneilan
Rua Particular
- Estrada Velha Rio De Janeiro -
Sao Paulo, KM 101
Jacarei, Sao Paulo
Caixa Postal 167, CEP 12305-330
Tel: 55-11-3958-2011
Fax: 55-11-3958-2670
E-Mail: dresserjac@uol.com.br

Canada

DI Canada, Inc.
2135 Meadowpine Blvd. Mississauga,
Ontario L5N 6L5
Canada
Tel: 905-335-3529
Fax: 905-826-9106
E-Mail: Lance.Barette@dresser.com

China

Dresser Industries, Inc.
Room #2404,
Capital Mansion
No. 6 Xin Yuan Nan Road Beijing,
People's Republic of China 100004
Tel: 86-10-84862440/1/2/3/4
Fax: 86-10-84862445
E-Mail: dresser@public3.bta.net.cn

France

Dresser Europe GmbH
Division Instrumentation
206 Rue des Campanules Le Mandinet
F 77185 Lognes, France
Tel: 33-1-60372530
Fax: 33-1-60372539
E-Mail: europe@wanadoo.fr

Germany

Dresser Europe GmbH
Postfach 11 20
Max-Planck-Str. 1
D-52499 Baesweiler, Germany
Tel: 49-24-01-8080
Fax: 49-24-01-7027
E-Mail: jbiermans@dresserbae.de

Germany

Ebro Electronic GmbH
Peringerstr 10D-85055
Ingolstadt, Germany
Tel: 49-84-1-95478-0
Fax: 49-84-1-95478-80
E-Mail: info@ebro.de

Japan

Dresser Japan Ltd.
Room 818, Shin Tokyo Building
3-1 Marunouchi 3-Chome,
Chiyoda-ku, Tokyo, Japan
Tel: 813-3201-1501
Fax: 813-3213-6567
E-Mail: yuichi.yamamoto@dresserjapan.co.jp

Korea

Dresser International, S.A
#2015 Kuk Dong Bldg.
Room 2017
60-1, 3-KA, Choongmu-Ro, Chung-ku
Seoul, Korea 100-705
Tel: 82-2-2274-0792
Fax: 82-2-2274-0794
E-Mail: dkisjlee@chollian.net

Mexico

Dresser Instruments S.A. De C.V.
Mexico Operations
Henry Ford No. 114
Esq. Foulton
Fracc. Industrial San Nicolas
54030 Tlalnepantla, Edo De Mexico
Tel: (52)55-53-10-72-17
(52)55-53-10-89-83
(52)55-53-10-28-29
(52)55-53-10-28-75
Fax: (52)55-53-10-26-08
E-Mail: mendiet@avantel.net

Saudi Arabia

Dresser Al Rushaid Valve &
Instrument Co. (DARVICO)
P.O. Box 10145
Jubail Industrial City
Saudi Arabia 31961
Tel: 966-3-341-0278
Fax: 966-3-341-7624
E-Mail: bill_dumasia@darvico.com
E-Mail: sam_dastur@darvico.com

Singapore

Dresser Singapore
Instrument Operations
Block 1004 Toa Payoh North
#07-15/17 Singapore 318995
Tel: 65-6252-6602
Fax: 65-6252-6603
E-Mail: john.wong@dresser.com.sg

United Kingdom

Dresser Europe GmbH
East Gillibrands, Skelmersdale
Lancashire, WN8 9TU
United Kingdom
Tel: 44-16-95-52600
Fax: 44-16-95-52693
E-Mail: sales@dresser-instrument.co.uk

Venezuela

Manufactures Petroleras Venezolanas
(M.P.V.)
KM 7 Carretera A
El Mojan Calle 18
#15B355 ZONA
Ind. Norte Sector Canchancha
Maracaibo Edo Zulia Venezuela
Tel: 58-261-757-9070
Fax: 58-261-757-9461
E-Mail: contactenos@mapvensa.com
E-Mail: ventasmpv@telcel.net.ve



Instruments

Visit our web site www.ashcroft.com

All specifications are subject to change without notice.
All sales subject to standard terms and conditions.
© Dresser Instruments, Dresser, Inc. CP15M 5P12/03